



# MySpot 20 Hinged Lockable Parking Barrier

**MySpot™ 20** is an attractive, strong hinged barrier that restricts access to an individual parking space. The barrier is unlocked by the use of a key and placed on the ground to allow entrance to the space. The post self-locks when it is pulled to the upright position.

MySpot 20 is constructed using high grade, heavy duty durable steel tubing. The unit is shipped completely assembled, ready to be bolted to the parking surface. The kit includes 2 keys and all the hardware required to anchor the unit to a concrete surface. The supplied Euro lock can be replaced in the field for special keying requirements.

### Applications

- Reserving designated parking spaces in garages, offices, shopping centers, hospitals, condominiums
- Blocking access to narrow streets and drive-ways
- Valet parking
- Handicap parking
- Parking lot management

### Installation

The MySpot 20 is a heavy duty barrier. As such, it should be installed on a solid surface such as concrete or masonry. Installation on asphalt requires special hardware. Please visit our web site [www.designatedparking.com](http://www.designatedparking.com) for information under "Products > Accessories".

The actual installation requires drilling 9 10mm (3/8") holes, inserting the provided anchors, then placing the pre-assembled barrier and tightening 9 security bolts.



*MySpot 20 guards individual parking spaces*

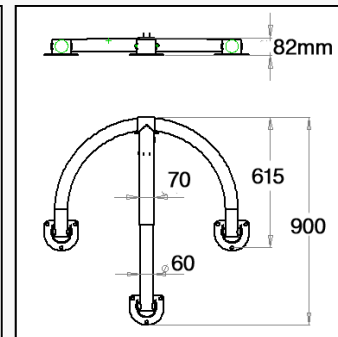
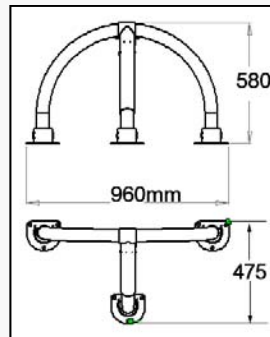
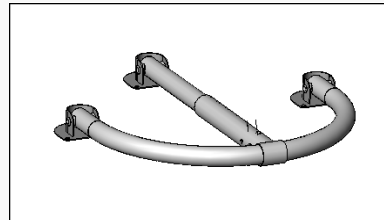

P/N	Weight	carton	Warranty	Time to install
01-6220	12Kg / 26lbs	100x100x9cm 39"x39"4"	1year	15 minutes



10 Ridge Rd  
West Orange, NJ 07052  
USA

Tel: 1.973.669.8214  
Fax: 1.973.669.5161  
Email: [info@dp-corp.com](mailto:info@dp-corp.com)  
WEB: [www.dp-corp.com](http://www.dp-corp.com)